

18 mm	Liczba skrzydeł n / Quantity of doors n	n = 2	n = 3	n = 4	n = 5	n = 6	n = 7	n = 8
	Wysokość płyty hP [mm] / Board height hP [mm]	hP = H-40						
Szerokość płyty bP [mm] / Board width bP [mm]	$bP = (S+20)/2$	$bP = (S+43)/3$	$bP = (S+66)/4$	$bP = (S+89)/5$	$bP = (S+112)/6$	$bP = (S+134)/7$	$bP = (S+157)/8$	
Długość kątownika górnego, ceownika oraz łącznika R [mm] Upper angle profile, C-profile and connector length R [mm]	R = bP-37							
Długość rączki LR [mm] / Handle length LR [mm]	LR = H-38							

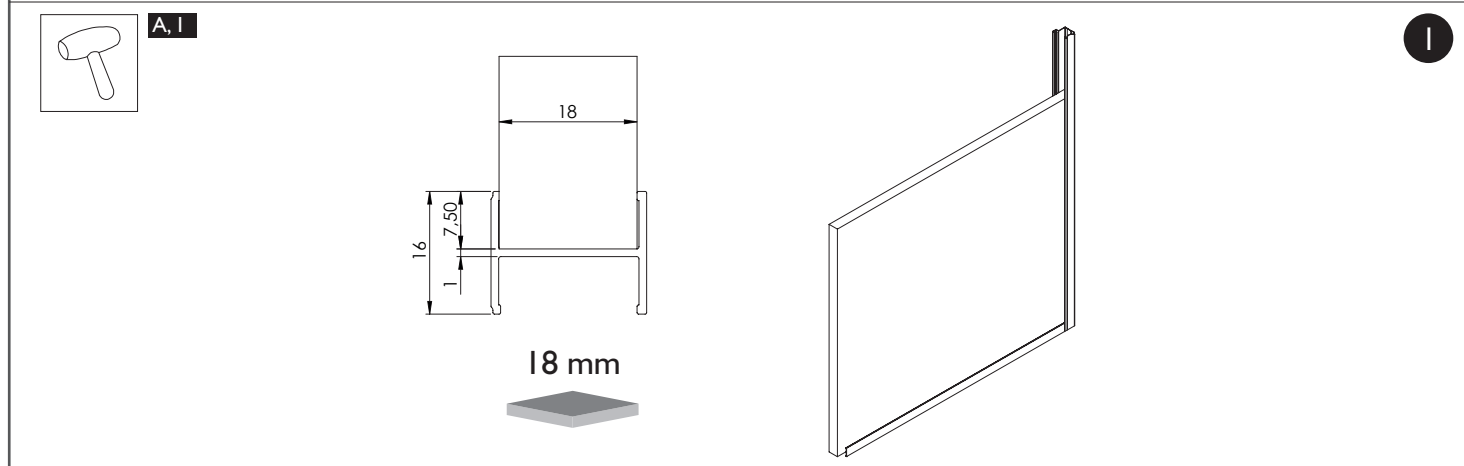
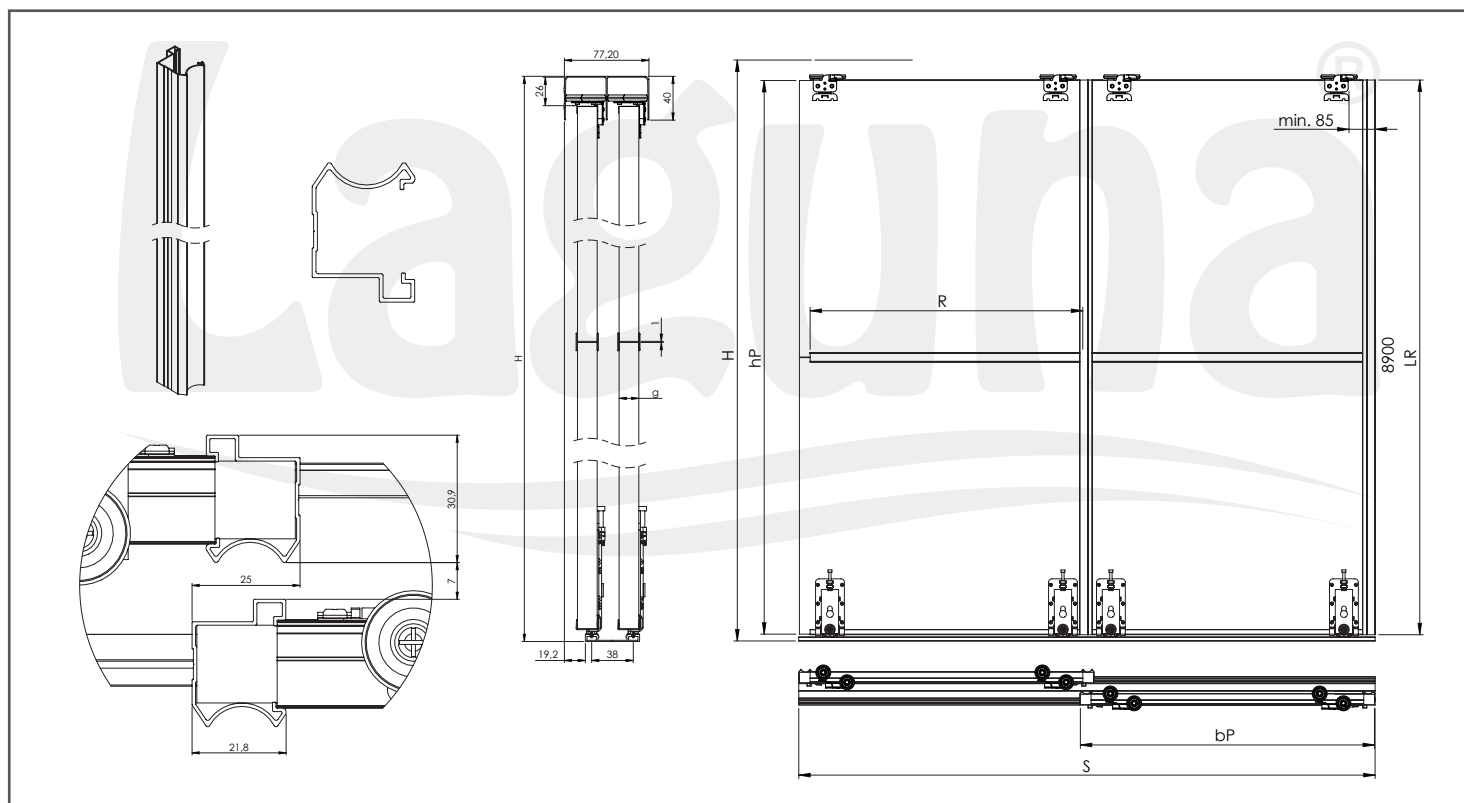
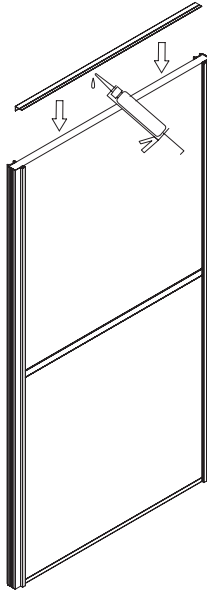
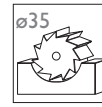
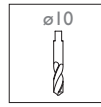
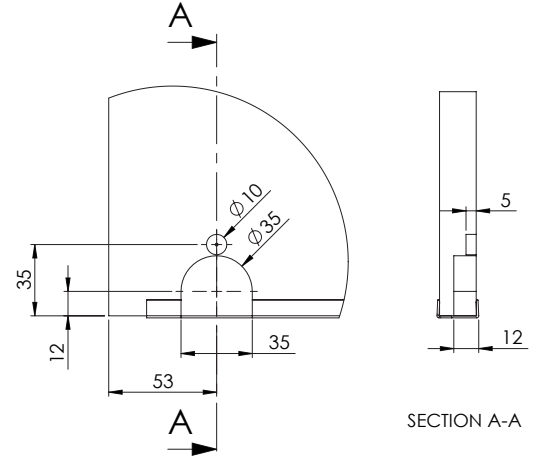
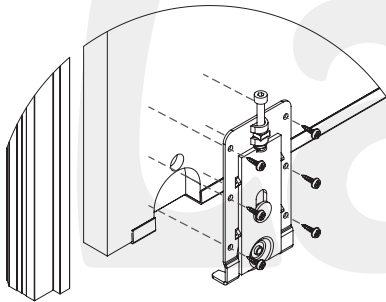
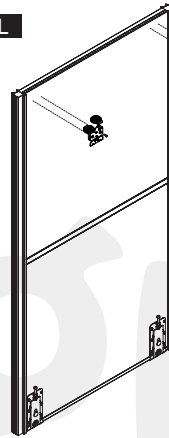

**G****2****H****3****E, K****4****F, L****5.1**

Montaż prowadnika Solid Pro z rączką symetryczną  
Solid Pro guide installation with a symmetrical handle

Rekomendowane wkręty:  
U-5-4x16

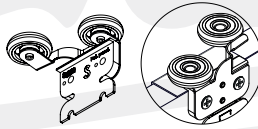
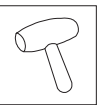
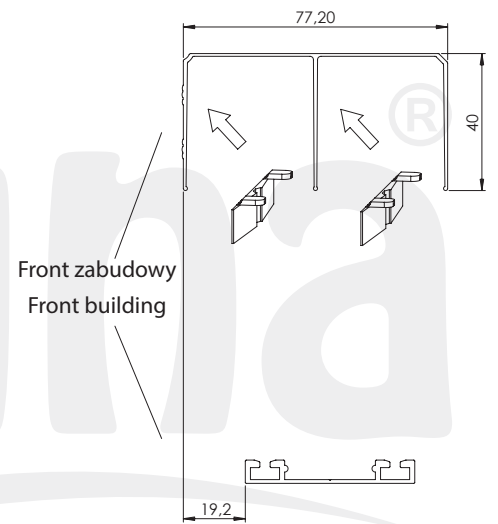
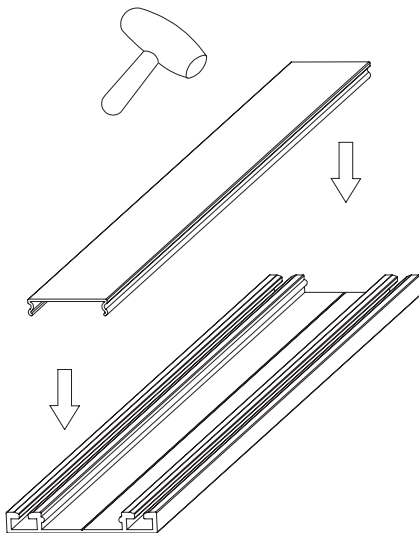
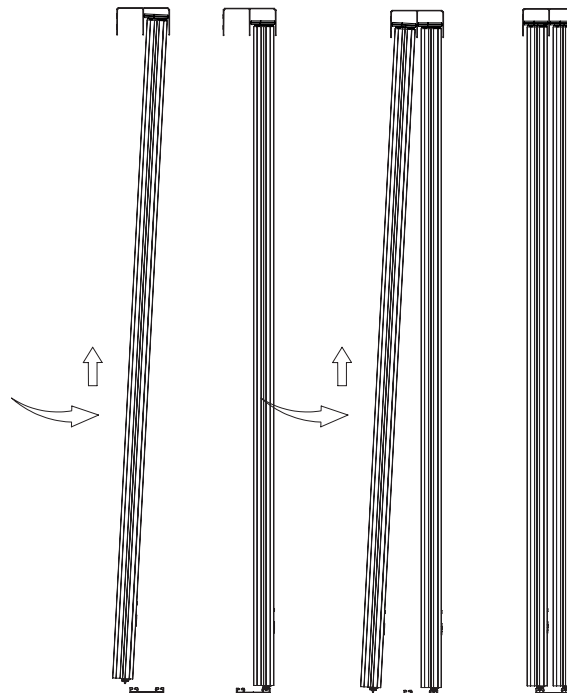
**5.2****B, C, J****6****C, D****7****8**

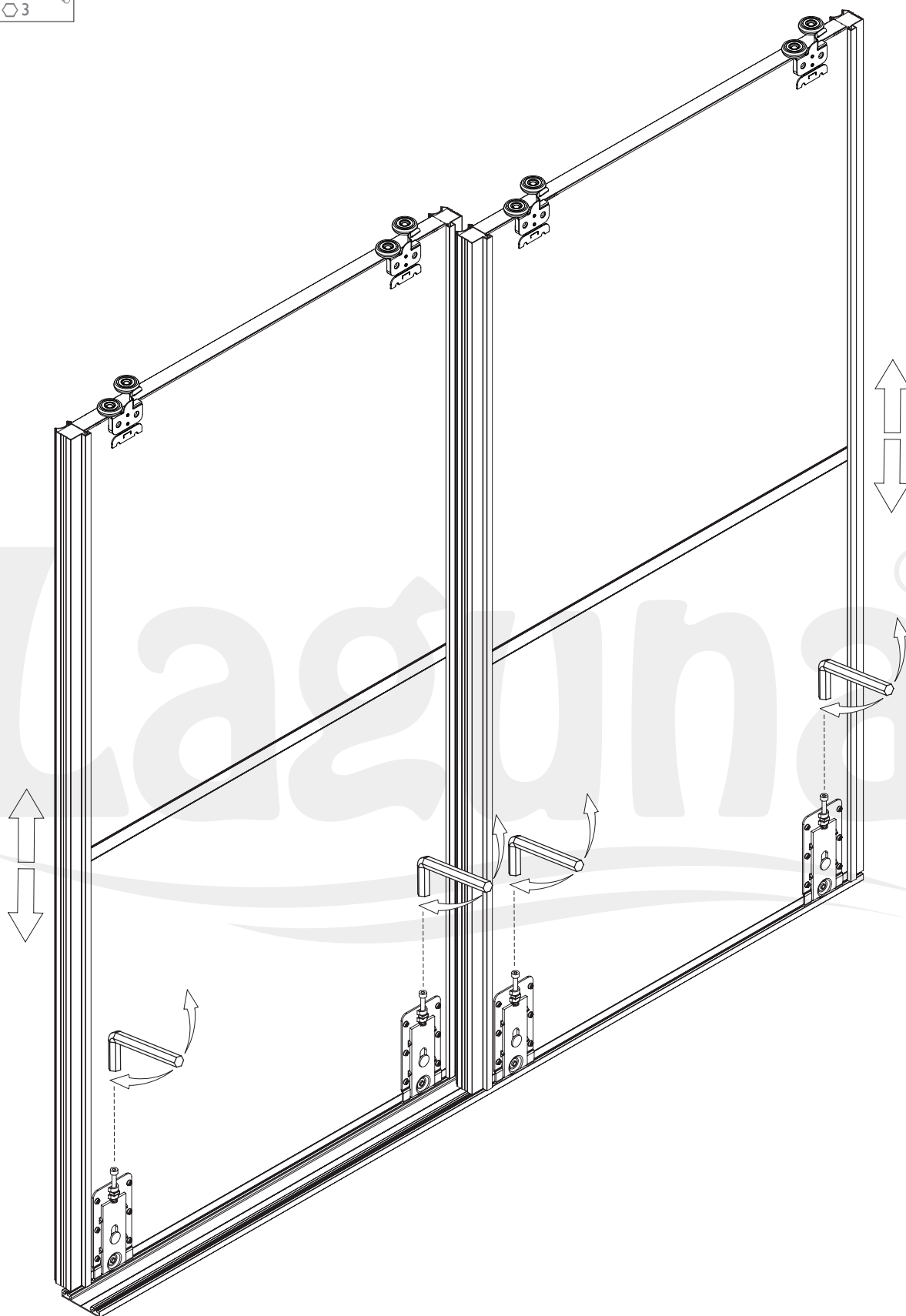
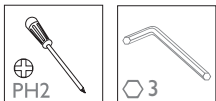

Zaleca się postępowanie zgodnie z niniejszą instrukcją przy użyciu odpowiednich narzędzi, zgodnych ze wskazaniami. W przypadku elementów, których powierzchnia może być ostra należy stosować środki ochrony indywidualnej oraz zabezpieczenie obszaru pracy. Firma Laguna Fabryka Okuć Sp. z o.o. Sp. k. uchyla się od odpowiedzialności za działania wynikające z postępowania niezgodnego z niniejszą instrukcją.

*It is recommended that you follow these instructions using the appropriate tools as indicated. In the case of elements whose surface can be sharp, use personal protective equipment and work area protection. The company Laguna Hardware Factory Limited Liability Limited Partnership refrains from liability for actions resulting from conduct incompatible with this instruction.*