

# INTERO

na torze RAMA  
lower track RAMA

50  
kg

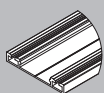

Rama



18 mm



4 mm

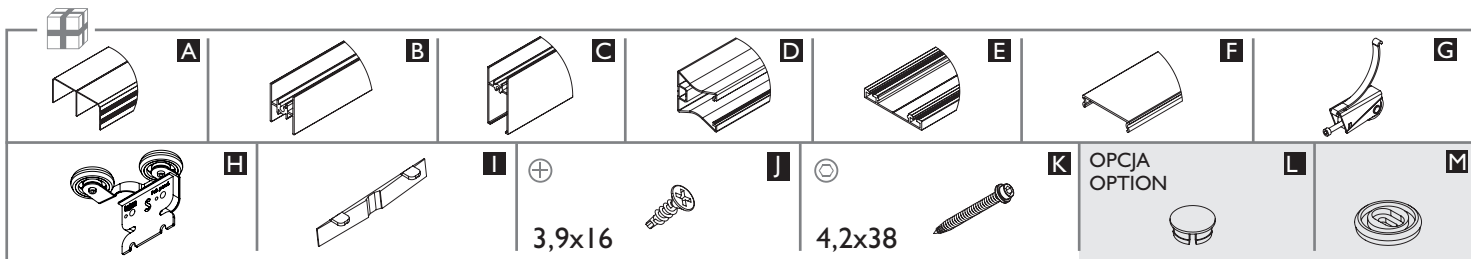
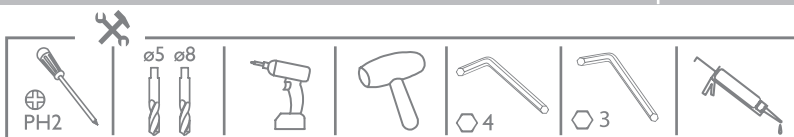

18 mm PLYTA   BOARD	Liczba skrzydeł n / Quantity of doors n	n = 2	n = 3	n = 4	n = 5	n = 6	n = 7	n = 8
	Wysokość płyty hP [mm] / Board height hP [mm]		hP = H-121					
Szerokość płyty bP [mm] / Board width bP [mm]		$bP = (S+8)/2$	$bP = (S+32)/3$	$bP = (S+56)/4$	$bP = (S+80)/5$	$bP = (S+104)/6$	$bP = (S+128)/7$	$bP = (S+152)/8$
Długość ramiaka dolnego, górnego oraz łącznika R [mm] Upper, lower rail and connector lenght R [mm]		R = bP-46						
Długość rączki LR [mm] / Handle lenght LR [mm]		LR = H-40						
2 x 4 mm SZKŁO   GLASS	Liczba skrzydeł n / Quantity of doors n	n = 2	n = 3	n = 4	n = 5	n = 6	n = 7	n = 8
Wysokość lustra/szkła hL [mm] / Mirror height hL [mm]		hL = H-112						
Szerokość lustra/szkła bL [mm] / Mirror width bL [mm]		$bL = (S+34)/2$	$bL = (S+71)/3$	$bL = (S+108)/4$	$bL = (S+145)/5$	$bL = (S+182)/6$	$bL = (S+219)/7$	$bL = (S+256)/8$
Długość ramiaka dolnego, górnego oraz łącznika R [mm] Upper, lower rail and connector lenght R [mm]		R = bL-59						
Długość rączki LR [mm] / Handle lenght LR [mm]		LR = H-40						

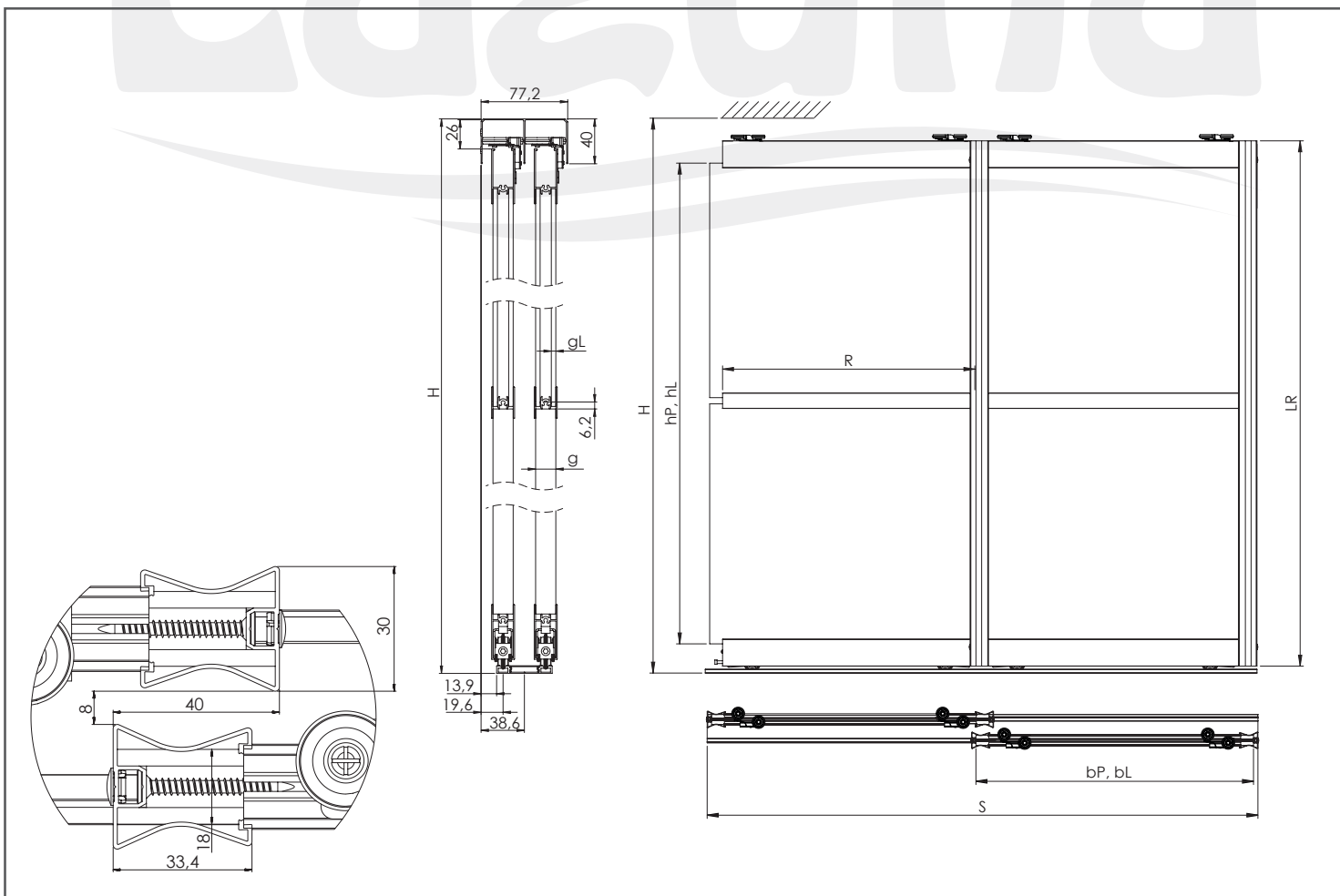



C, D, G, K, L

1

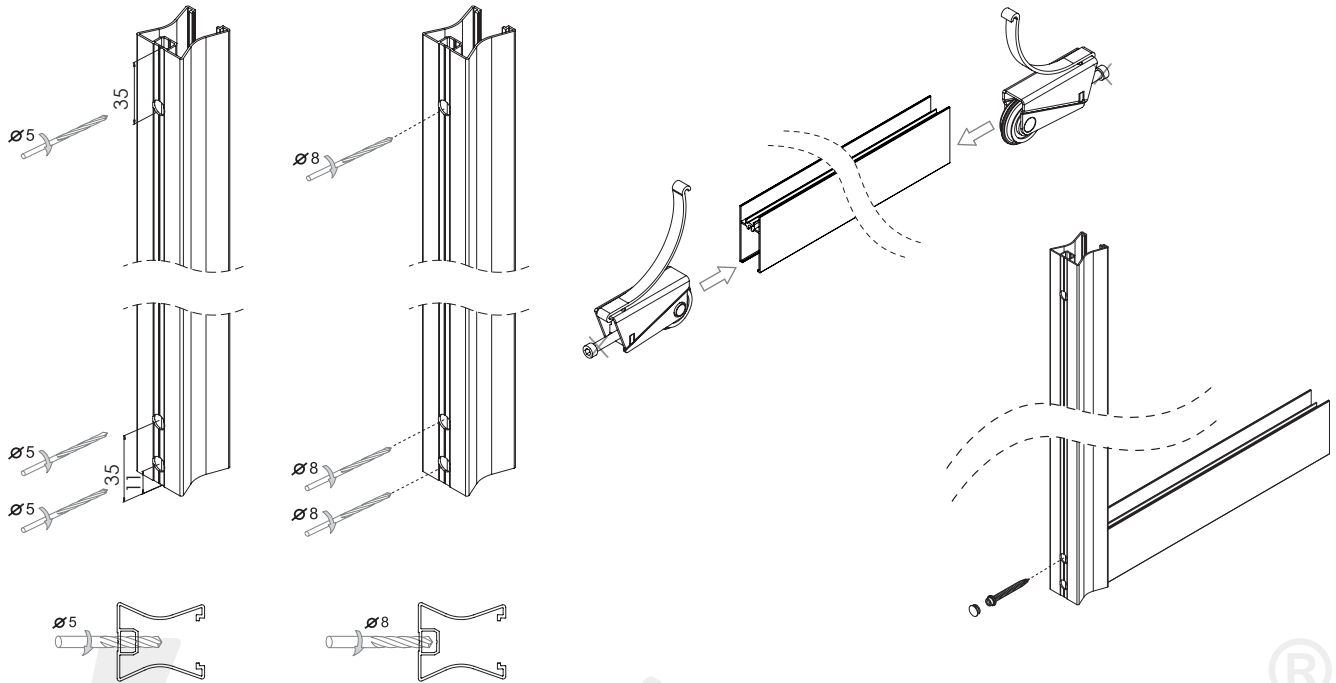

2.1



2.2

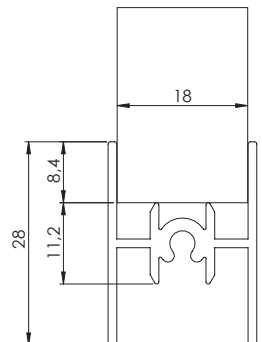
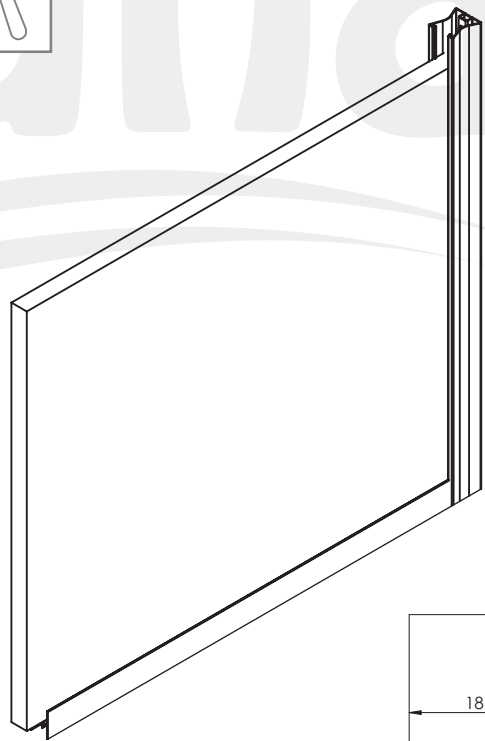
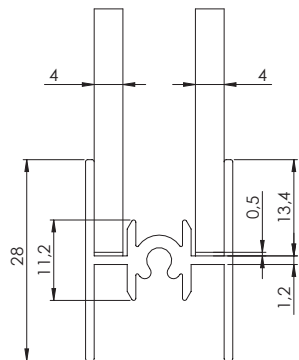
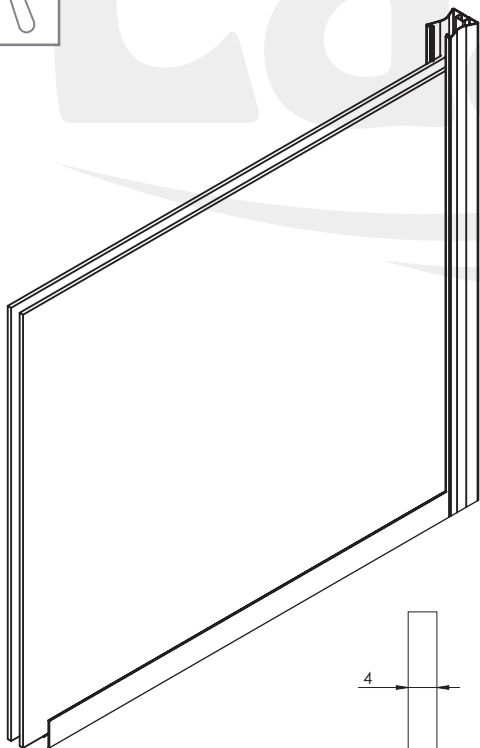

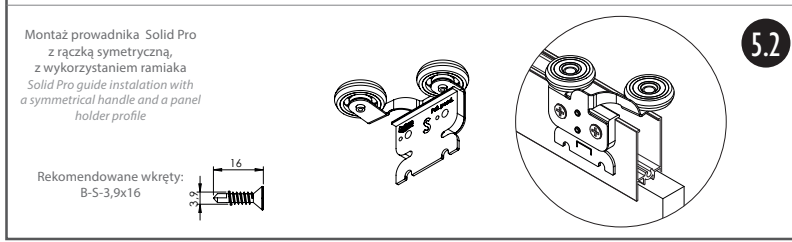
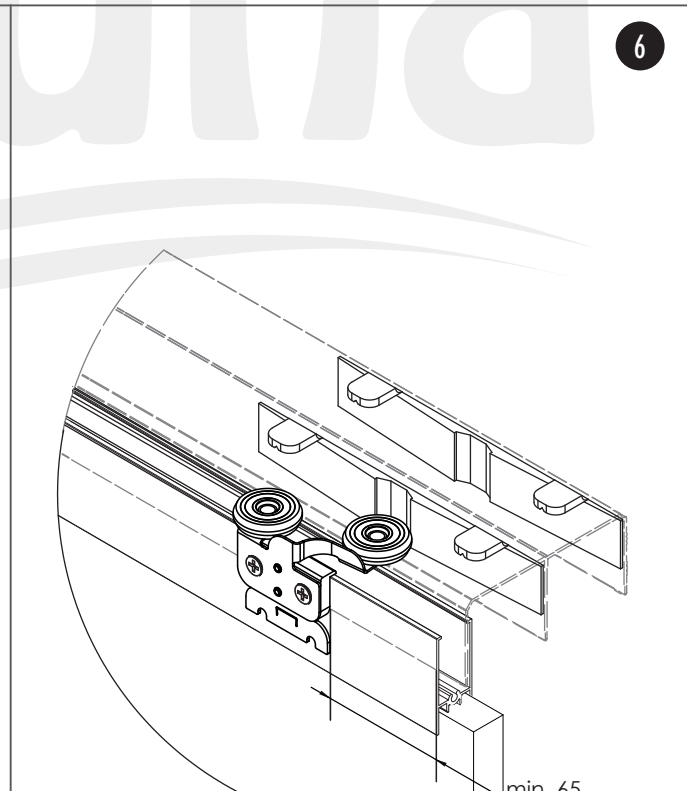
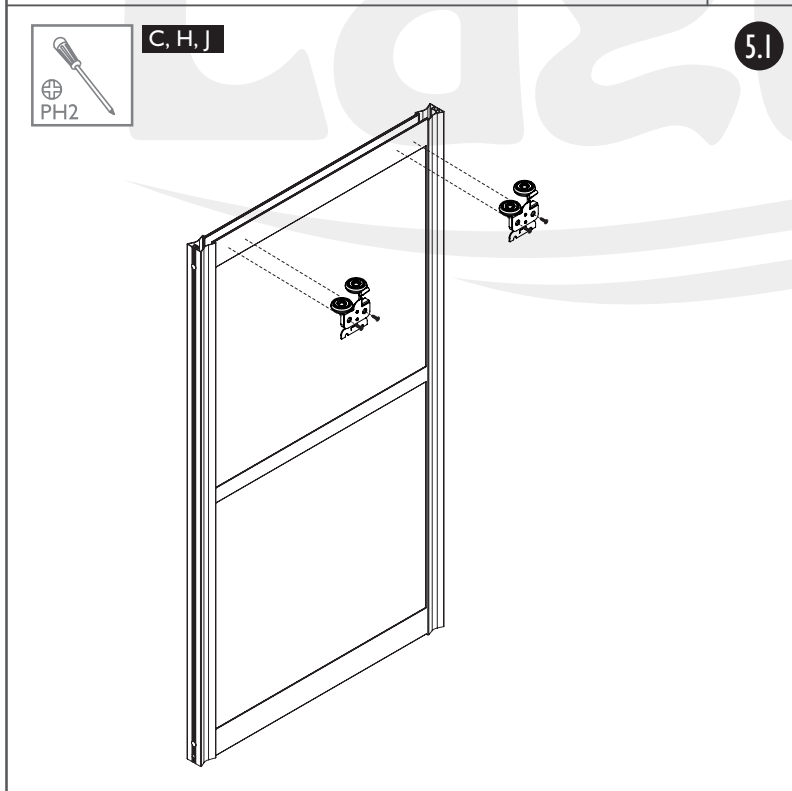
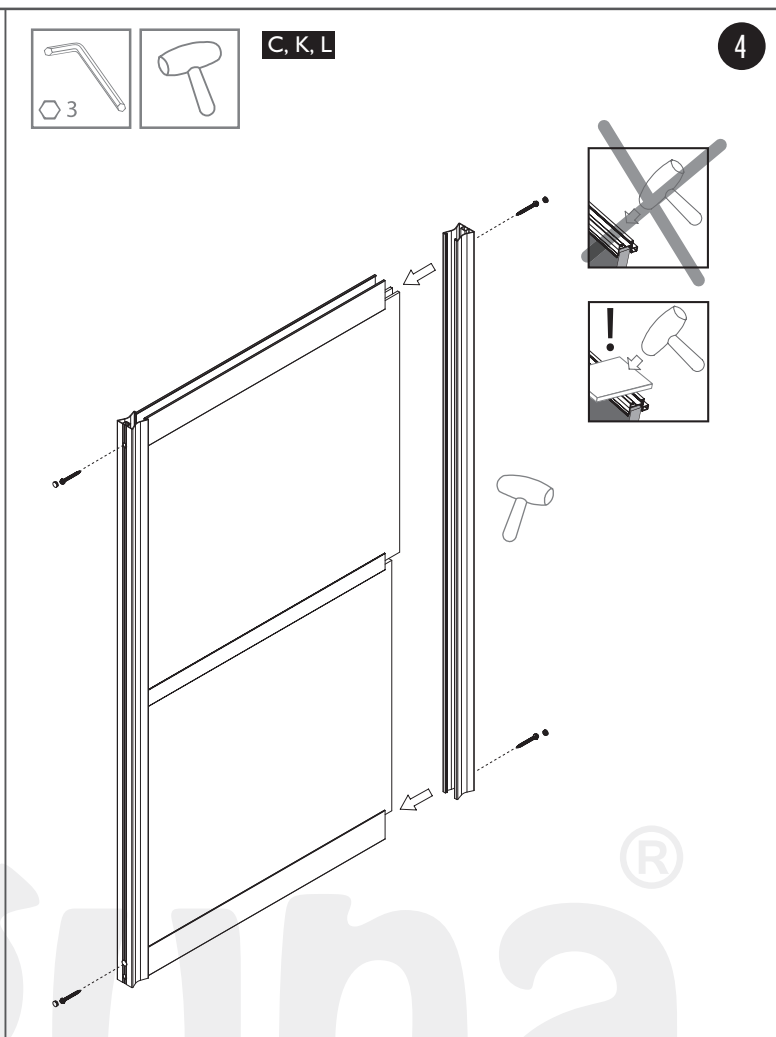
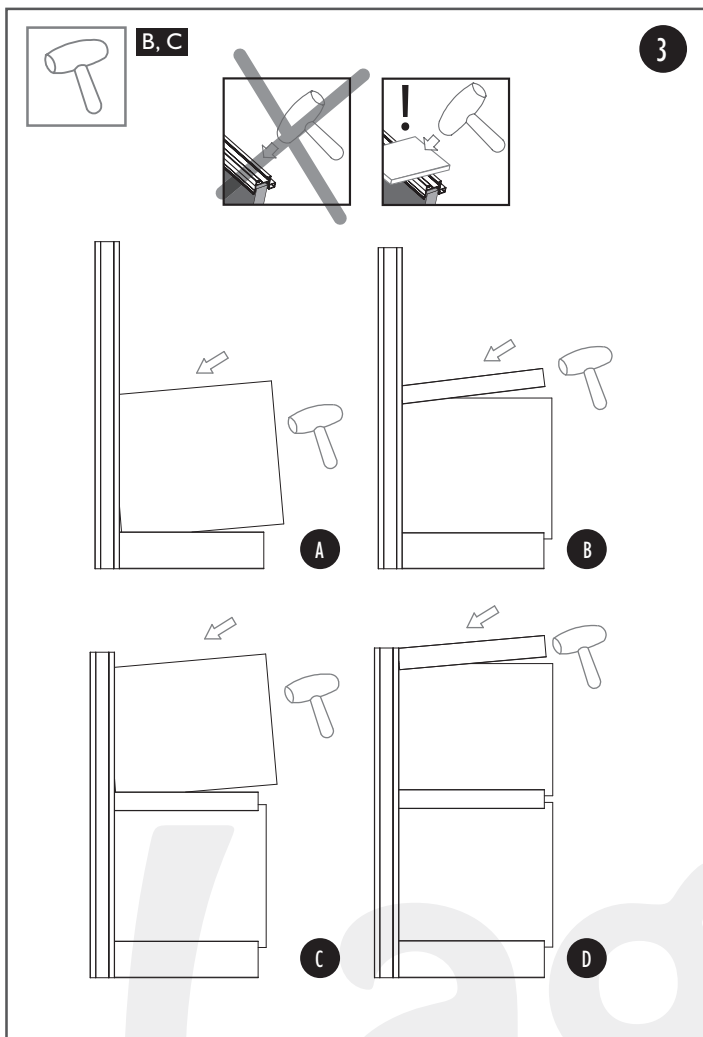



A, E, F, I

7

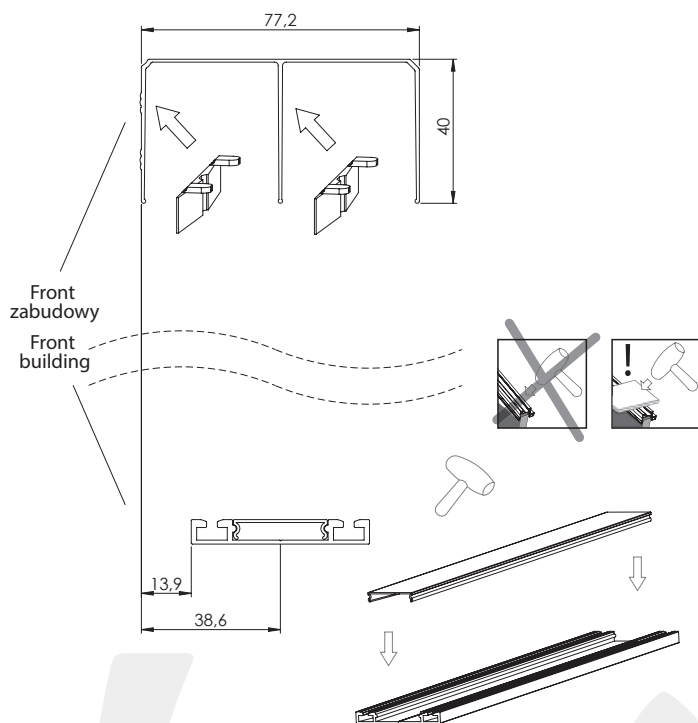

8

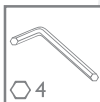
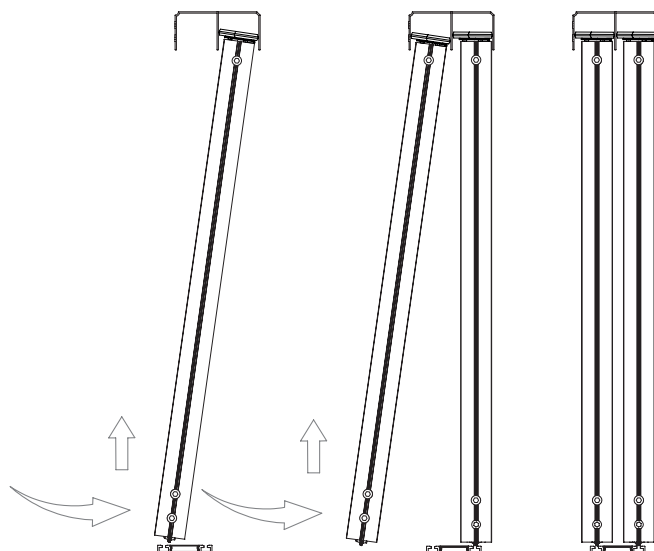

9

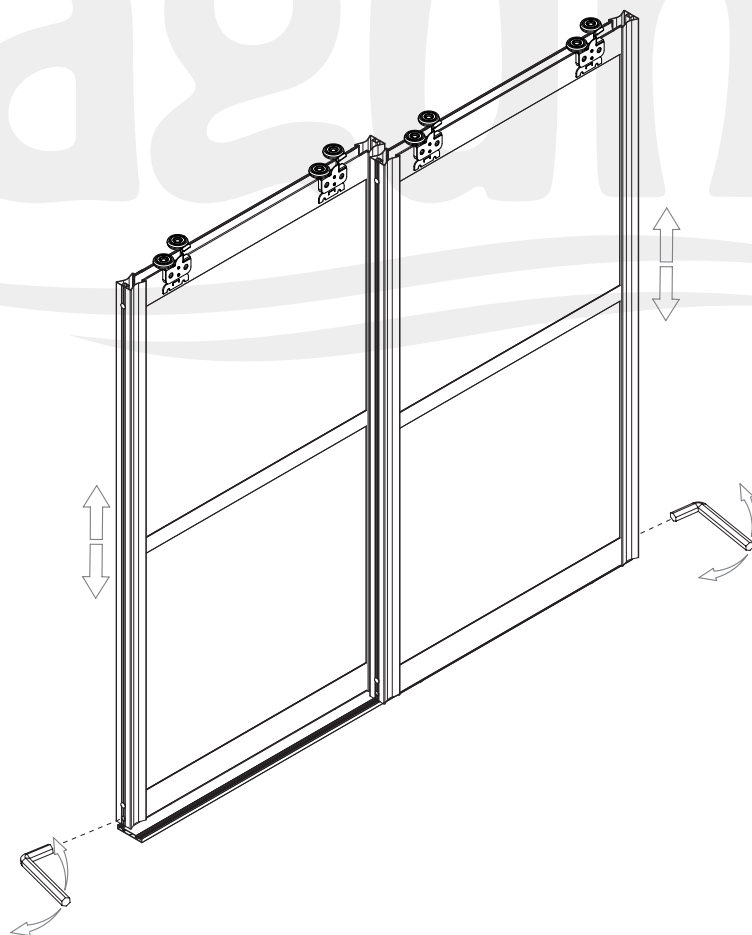

Zaleca się postępowanie zgodnie z niniejszą instrukcją przy użyciu odpowiednich narzędzi, zgodnych ze wskazaniami. W przypadku elementów, których powierzchnia może być ostra należy stosować środki ochrony indywidualnej oraz zabezpieczenie obszaru pracy. Firma Laguna Fabryka Okuć Sp. z o.o. Sp. k. uchyła się od odpowiedzialności za działania wynikające z postępowania niezgodnego z niniejszą instrukcją.

*It is recommended that you follow these instructions using the appropriate tools as indicated. In the case of elements whose surface can be sharp, use personal protective equipment and work area protection. The company Laguna Hardware Factory Limited Liability Limited Partnership refrains from liability for actions resulting from conduct incompatible with this instruction.*